

Dell PowerEdge 6 Gbps SAS  
HBA and Internal Tape  
Adapter  
**User's Guide**



# Notes, Cautions, and Warnings



**NOTE:** A NOTE indicates important information that helps you make better use of your computer.



**CAUTION:** A CAUTION indicates potential damage to hardware or loss of data if instructions are not followed.



**WARNING:** A WARNING indicates a potential for property damage, personal injury, or death.

---

**Information in this publication is subject to change without notice.**

**© 2012 Dell Inc. All rights reserved.**

Reproduction of these materials in any manner whatsoever without the written permission of Dell Inc. is strictly forbidden.

Trademarks used in this text: Dell™, the DELL logo, PowerEdge™, and OpenManage™ are trademarks of Dell Inc.; Microsoft®, Windows® and Windows Server® are either trademarks or registered trademarks of Microsoft Corporation in the United States and/or other countries; SUSE® is a registered trademark of Novell, Inc. in the United States and other countries; Red Hat® and Red Hat Enterprise Linux® are registered trademarks of Red Hat Inc. in the United States and other countries.

Other trademarks and trade names may be used in this document to refer to either the entities claiming the marks and names or their products. Dell Inc. disclaims any proprietary interest in trademarks and trade names other than its own.

UCS-71, UCS-70, and UCSM-70

# Contents

1	Overview . . . . .	5
	<b>Hardware Architecture</b> . . . . .	6
	<b>Operating System Support</b> . . . . .	7
	<b>Related Documentation</b> . . . . .	7
	<b>Contacting Dell</b> . . . . .	8
2	PowerEdge 6 Gbps SAS HBA and Internal Tape Adapter Features . . . . .	9
	<b>LED Port Activity Feature for 6 Gbps SAS HBA Only</b> . . . . .	11
3	Hardware Installation . . . . .	13
	<b>Installing the 6 Gbps SAS HBA and Internal Tape Adapter Cards</b> . . . . .	13
4	Driver Installation . . . . .	17
	<b>Installing the Windows Driver</b> . . . . .	18
	Creating the Driver Media . . . . .	18
	Pre-Installation Requirements . . . . .	18
	Installing the Driver During a Windows Server 2003 Operating System . . . . .	19

	Installing the Driver During a Windows Server 2008 or Windows Server 2008 R2 . . . . .	20
	Installing a Windows Server 2003, Windows Server 2008 or Windows Server 2008 R2 Driver for a New Controller . . . . .	21
	Updating the Windows Driver . . . . .	22
	<b>Installing Linux Driver . . . . .</b>	<b>23</b>
	Installing the RPM Package With DKMS Support . . . . .	23
	Upgrading the Kernel . . . . .	24
<b>5</b>	<b>6 Gbps SAS HBA BIOS . . . . .</b>	<b>25</b>
	<b>POST Messages . . . . .</b>	<b>25</b>
	BIOS Fault Code Messages . . . . .	25
	<b>Configuration Utility . . . . .</b>	<b>26</b>
	Using Configuration Utility . . . . .	26
	Functions of the Configuration Utility . . . . .	26
	Exit Screen . . . . .	27
<b>6</b>	<b>Troubleshooting . . . . .</b>	<b>29</b>
	<b>General Issues . . . . .</b>	<b>29</b>
	<b>Configuration Utility Error Messages . . . . .</b>	<b>29</b>
	<b>BIOS Error Messages . . . . .</b>	<b>31</b>
<b>A</b>	<b>Updating the Firmware . . . . .</b>	<b>35</b>
	<b>Firmware Package Update Utility . . . . .</b>	<b>35</b>

# Overview

The Dell PowerEdge 6 Gbps SAS HBA and Internal Tape Adapter cards are part of the Dell Serial-Attached SCSI (SAS) controllers solutions.

The 6 Gbps SAS HBA and Internal Tape Adapter cards have the following characteristics:

- T10 SAS 2.0 compliance with 6 Gbps throughput
- Support for Dell-supported external SAS tape devices and RAID Bunch of Disks (RBOD) connectivity (6 Gbps SAS HBA)
- Support for Dell-supported internal SAS tape devices (Internal Tape Adapter)
- Standard half-length, half-height PCI-e cards
- Supported with PCI-e x8 link width
- Supported on platforms with PCI-e x8 and x16 connectors
- Communicate with SAS devices using 2x4 mini-SAS connectors
- Support for LT03 060, LT04, and LT05 tape drives
- Support for full hardware Transport Layer Retry (TLR), to improve maximum tape throughput
- PCI-e 2.0 compliant to key features.

# Hardware Architecture

Figure 1-1 displays the hardware architecture of the 6 Gbps SAS HBA. The Internal Tape Adapter has a similar architecture except that the SAS connectors are internal.

**Figure 1-1. Hardware Architecture of the 6 Gbps SAS HBA and Internal Tape Adapter**

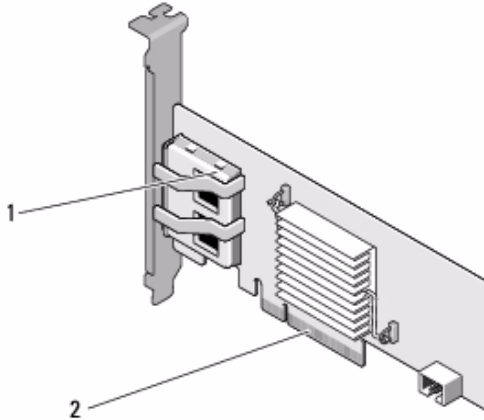

- 1 2x4 external SAS connectors
- 2 PCI-e connector

# Operating System Support

The 6 Gbps SAS HBA and Internal Tape Adapter cards support the following operating systems:

- Microsoft Windows Server 2003 family
- Microsoft Windows Server 2008 family, including Hyper-V Virtualization
- Microsoft Windows Server 2008 R2
- Red Hat Enterprise Linux version 5 update 7 and version 6 Service Pack 1
- SUSE Linux Enterprise Server version 10 Service Pack 4 (64-bit only), and version 11 Service Pack 2 (64-bit only)
- VMware ESX 4.1 Update 1 and ESXi 5.0.



**NOTE:** For the latest list of supported operating systems and driver installation instructions, see the system documentation on the Dell Support website at [support.dell.com/manuals](http://support.dell.com/manuals). For specific operating system service pack requirements, see the **Drivers and Downloads** section on the Dell Support website at [support.dell.com](http://support.dell.com).

## Related Documentation

- To read and download product specific documentation, go to [support.dell.com/manuals](http://support.dell.com/manuals), and follow the instructions on the screen. You can either type in your Service Tag, choose your product from the list of models, log in to your account, or click on any of the individual components.
- For storage controller specific documentation, go to [support.dell.com/manuals](http://support.dell.com/manuals) and click **Storage Controllers**.

## Contacting Dell



**NOTE:** If you do not have an active Internet connection, you can find contact information on your purchase invoice, packing slip, bill, or Dell product catalog.

Dell provides several online and telephone-based support and service options. Availability varies by country and product, and some services may not be available in your area. To contact Dell for sales, technical support, or customer service issues:

- 1 Visit [support.dell.com](https://support.dell.com).
- 2 Select your support category.
- 3 If you are not a U.S. customer, select your country code at the bottom of the page, or select **All** to see more choices.
- 4 Select the appropriate service or support link based on your need.



# PowerEdge 6 Gbps SAS HBA and Internal Tape Adapter Features

This section provides the specifications of the Dell PowerEdge 6 Gbps SAS HBA and Internal Tape Adapter cards.

Table 2-1 compares the specifications of the 6 Gbps SAS HBA and the Internal Tape Adapter cards.

**Table 2-1. 6 Gbps SAS HBA and Internal Tape Adapter Specifications**

Specification	6 Gbps SAS HBA	Internal Tape Adapter
SAS technology	Yes	Yes
Support for x4 or x8 PCI-e host interface	Yes	Yes
Form factor	Half-height, Half-length PCI adapter	Half-height Half-length PCI adapter
I/O Controller (IOC) LSI SAS 2008	LSI SAS 2008 Core speed: 533 MHz	LSI SAS 2008 Core speed: 533 MHz
Operating voltage requirements	+12 V, +3.3 V, +3.3 Vaux	+12 V, +3.3 V, +3.3 Vaux
Communication to the system	PCI-e lanes	PCI-e lanes
Communication to end devices	SAS links	SAS links
SAS connectors	2x4 external	2x4 internal
Lead free	Yes	Yes

**Table 2-1. 6 Gbps SAS HBA and Internal Tape Adapter Specifications (continued)**

<b>Specification</b>	<b>6 Gbps SAS HBA</b>	<b>Internal Tape Adapter</b>
Supported operating systems	Microsoft Windows Server 2003 family Microsoft Windows Server 2008 family, Windows Server 2008 R2 Red Hat Enterprise Linux version 5 update 7 and later Red Hat Enterprise Linux version 6 SP 1 and later SUSE Linux Enterprise Server version 10 SP 4 and later (64-bit only) SUSE Linux Enterprise Server version 11 and SP 2 (64-bit only).	
Dell-compliant SAS and SATA compatibility	Yes	Yes
Dell-supported direct connected end devices	Dell-supported external tape devices, Dell supported external RBODs.	Dell-supported internal tape devices.
Hardware-based RAID support	No	No

# LED Port Activity Feature for 6 Gbps SAS HBA Only

The 6 Gbps SAS HBA controllers are equipped with port activity or status LEDs. The LEDs enable you to quickly determine the status of an external SAS port. Each x4 connector has its own set of LEDs.

Table 2-2 describes the color of the LEDs and corresponding SAS port state.

**Table 2-2. x4 Connector LEDs Description**

LED Color	SAS Port State
Off	It indicates one of the following: <ul style="list-style-type: none"><li>• Power is off.</li><li>• Port has been reset.</li><li>• Either all links in the port are disconnected or the cable is disconnected.</li></ul>
Green	All links in the port are connected and <i>functional</i> .
Amber	One or more links in the port is not connected. This is only applicable in a wide port configuration.



# Hardware Installation

This chapter describes how to install the Dell PowerEdge 6 Gbps SAS HBA and Internal Tape Adapter cards.

The Dell PowerEdge 6 Gbps SAS HBA and Internal Tape Adapter cards are either available with the system or as a kit.

When the Dell PowerEdge 6 Gbps SAS HBA and Internal Tape Adapter cards are available:

- With the system, the drivers will be installed and ready to use.
- As a kit, you need to install the drivers. For more information see "Driver Installation" on page 17.

## Installing the 6 Gbps SAS HBA and Internal Tape Adapter Cards



**CAUTION:** Many repairs may only be done by a certified service technician. You should only perform troubleshooting and simple repairs as authorized in your product documentation, or as directed by the online or telephone service and support team. Damage due to servicing that is not authorized by Dell is not covered by your warranty. Read and follow the safety instructions provided with the product.

- 1 Unpack the 6 Gbps SAS HBA or Internal Tape Adapter and check for damage.



**NOTE:** Contact Dell if the controller is damaged.

- 2 Turn off the system and attached peripherals, and disconnect the system from the electrical outlet.

For more information on power supplies, see your system's *Hardware Owner's Manual* or the *User's Guide*.

- 3 Disconnect the system from the network and remove the cover of the system.

For more information on opening the system, see your system's *Hardware Owner's Manual* or the *User's Guide*.

- 4 Select an appropriate PCI-e slot.

When adding a 6 Gbps SAS HBA or Internal Tape Adapter, remove the blank filler bracket on the back of the system aligned with the PCI-e slot you have selected.

**NOTE:** For more information about your system's PCI-e slots, see your system's *Hardware Owner's Manual*.

5 Align the controller with the PCI-e slot you have selected.

6 Insert the controller in the PCI-e slot. See Figure 3-1.

**NOTE:** Figure 3-1 displays the 6 Gbps SAS HBA, but the installation instructions in this section are common for the 6 Gbps SAS HBA and Internal Tape Adapter.

**Figure 3-1. Installing a 6 Gbps SAS HBA**

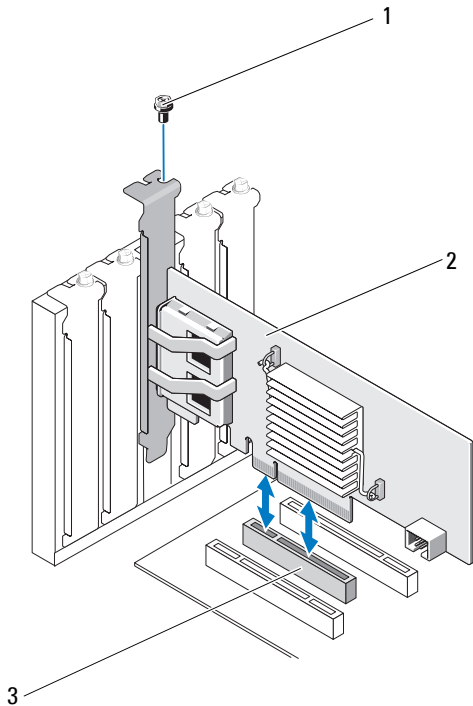

1 bracket screw

2 6 Gbps SAS HBA

3 PCI-e slot

- 7 Tighten the bracket screw, if any, or use the system's retention clips to secure the controller to the system's chassis.
- 8 For the Internal Tape Adapter card, connect the cables from the end devices to the controller. See Figure 3-2.

 **NOTE:** Although the Internal Tape Adapter has two internal connectors, only one internal tape device is supported. Use the connector (on the card) labeled 'A'.

**Figure 3-2. Connecting the Cable for the Internal Tape Adapter**

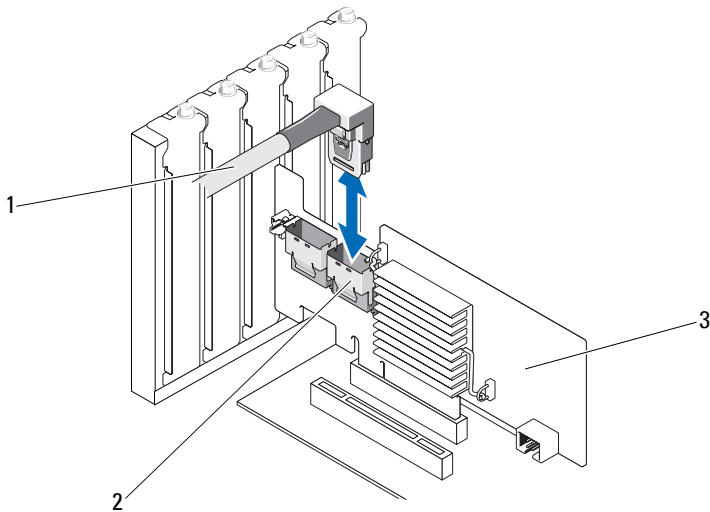

- |   |                       |   |                           |
|---|-----------------------|---|---------------------------|
| 1 | cable                 | 2 | SAS x4 internal connector |
| 3 | Internal Tape Adapter |   |                           |

- 9 For the 6 Gbps SAS HBA controller, connect the cable from the external tape device or enclosure to the adapter. See Figure 3-3.

 **NOTE:** The external cable can be connected to either of the two external connectors.

**Figure 3-3. Connecting the Cable for 6 Gbps SAS HBA**

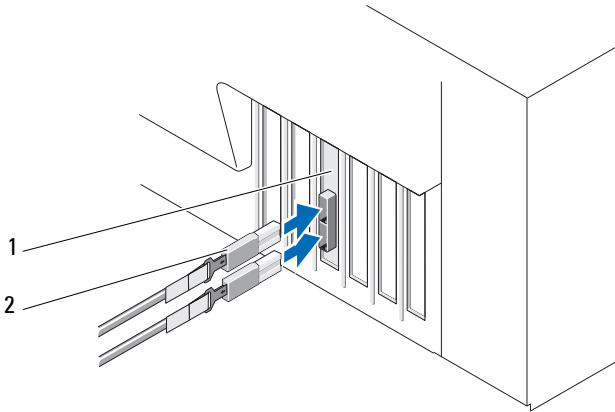

- 1 6 Gbps SAS HBA
- 2 Cable from the external tape device or enclosure

**10** Replace the cover of the system.

For more information on closing the system, see your system's *Hardware Owner's Manual* or the *User's Guide*.

**11** Reconnect the power cable(s) and network cables, and then turn on the system.

**NOTE:** For more information on connecting your 6 Gbps SAS HBA to an RBOD enclosure or external tape device see your system's *Hardware Owner's Manual* on the Dell Support website at [support.dell.com/manuals](http://support.dell.com/manuals).

**NOTE:** The 6 Gbps SAS HBA and Internal Tape Adapter cards do not support installing an operating system on a disk attached to the 6 Gbps SAS HBA or a tape drive.

**NOTE:** Hard drives are not supported on the Internal Tape Adapter.



# Driver Installation

The Dell PowerEdge 6 Gbps SAS HBA and Internal Tape Adapter cards require software drivers to operate with Microsoft Windows, Red Hat Enterprise Linux, and SUSE Linux operating systems.

This section contains procedures for installing drivers for the following operating systems:

- Microsoft Windows Server 2003 Server family
- Microsoft Windows Server 2008 Server family
- Windows Server 2008 R2
- Red Hat Linux version 5 Update 7
- SUSE Linux Enterprise Server version 10 Service Pack 4 (64-bit only), and version 11 Service Pack 2 (64-bit only).

A driver can be installed in the following three ways:

- During operating system installation
- After adding a new 6 Gbps SAS HBA or Internal Tape Adapter controller on an existing operating system
- Updating existing drivers.



**NOTE:** To ensure you have the latest version of any driver mentioned in this section, check the Dell Support website at [support.dell.com](http://support.dell.com). If a newer version exists, you can download the driver to your system.

# Installing the Windows Driver

This section documents the procedures used to install the Windows driver.

## Creating the Driver Media

To create the driver media:

- 1 Browse to the Download section for the system on the Dell Support website at [support.dell.com](http://support.dell.com).
- 2 Locate and download the latest 6 Gbps SAS HBA or Internal Tape Adapter card driver to the system.
- 3 Follow the instructions on the Dell Support website for extracting the driver to the media.

## Pre-Installation Requirements

Before you install the operating system:

- Read the Microsoft *Getting Started* document that is shipped with your operating system.
- Ensure that your system has the latest BIOS and firmware. Ensure that the latest driver is available for the installation. If required, download the latest BIOS, firmware, and driver updates from the Dell Support website at [support.dell.com](http://support.dell.com).
- Create a device driver media (diskette, USB drive, CD, or DVD).

## Creating the Device Driver Media

To create the device driver media, follow one of the methods described in the following sections:

### ***Downloading Drivers From the Dell Systems Service and Diagnostic Tools Media***

- 1 Insert the *Dell Systems Service and Diagnostics Tools* media into a system. The **Welcome to Dell Service and Diagnostic Utilities** screen is displayed.
- 2 Select your system model and operating system.
- 3 Click Continue.

- 4 From the displayed list of drivers, select the driver that you require and perform the following steps.
  - a Select the self-extracting zip file and click **Run**.
  - b Copy the driver to a diskette drive, CD, DVD, or USB drive.
  - c Repeat step 4 for all the drivers that you require.
- 5 During the operating system installation described in "Installing the Driver During a Windows Server 2003 Operating System" on page 19 and "Installing the Driver During a Windows Server 2008 or Windows Server 2008 R2" on page 20, use the media that you created with the **Load Driver** option to load mass storage drivers.

### ***Downloading Drivers From the Dell Support Website***

- 1 Go to [support.dell.com](http://support.dell.com).
- 2 Click **Drivers and Downloads**.
- 3 Enter the service tag of your system in the **Choose by Service Tag** field or select your system's model.
- 4 Select the appropriate **System Type, Operating System, Driver Language, and Category** from the respective drop-down lists.
- 5 It displays the drivers that are applicable to your selection. From the available list, download the drivers that you require to a diskette drive, USB drive, CD, or DVD.
- 6 During the operating system installation described in "Installing the Driver During a Windows Server 2003 Operating System" on page 19 and, use the media that you created with the **Load Driver** option to load mass storage drivers.

### **Installing the Driver During a Windows Server 2003 Operating System**

- 1 Boot the system using the Windows Server 2003 media.
- 2 Press the <F6> key when the message **Press F6 if you need to install a third party SCSI or RAID driver** is displayed.

A screen asking for additional controllers in the system is displayed.
- 3 Press the <S> key.

The system prompts for the driver media to be inserted.



**NOTE:** Use a formatted USB key to provide the driver. For additional details check the Dell Support website at [support.dell.com](http://support.dell.com).

- 4 Insert the driver media in the media drive and press <Enter>.

A list of SAS controllers is displayed.

- 5 Select the appropriate driver for the installed controller and press <Enter> to load the driver.



**NOTE:** If the version of the driver you provide does not match the version on your system a message may be displayed. To use the driver on the media, press <S>.

- 6 Press <Enter> to continue the installation process as usual.

## **Installing the Driver During a Windows Server 2008 or Windows Server 2008 R2**

- 1 Boot the system using the Windows Server 2008 or the Windows Server 2008 R2 media.
- 2 Follow the on-screen instructions until the following message is displayed: **Where do you want to install 2008;**
- 3 Select **Load driver...**  
The system prompts for the media to be inserted. Insert the installation media and browse to the proper location when prompted.
- 4 When prompted, select the appropriate card from the list, click **Next** and continue installation as usual.

## Installing a Windows Server 2003, Windows Server 2008 or Windows Server 2008 R2 Driver for a New Controller

- 1 Turn off the system.
- 2 Install the new controller in the system.
- 3 Turn on the system.  
The Windows operating system detects the new controller and displays a message.
- 4 The **Found New Hardware Wizard** screen displays the detected hardware device.
- 5 Click **Next**.
- 6 On the **Locate device driver** screen, select **Search for a suitable driver for my device** and click **Next**.
- 7 Make the **Driver Files** available and browse to the proper location from the **Locate Driver Files** screen.
- 8 Click **Next**.
- 9 The wizard detects and installs the appropriate device drivers for the new controller.
- 10 Click **Finish** to complete the installation.
- 11 Reboot the system if Windows instructs you to do so.



**NOTE:** The Windows Server 2008 R2 operating system includes a device driver to support the SAS controllers. The system automatically detects the new controller and installs the driver. Check the version of the driver installed by Windows and update if necessary.

## Updating the Windows Driver

To update the Windows driver for the 6 Gbps SAS HBA or Internal Tape Adapter card that is already installed on your system, follow the steps given below:



**NOTE:** It is important that you close all applications on your system before you update the driver.

- 1 Depending upon your operating system, choose the appropriate action from the following list:
  - For Windows Server 2003:  
Click **Start**→ **Settings**→ **Control Panel**→ **System**.
  - For Windows Server 2008:  
Click **Start**→ **Settings**→ **Control Panel**→ **System**.
  - For Windows Server 2008 R2:  
Click **Start** → **Control Panel**→ **System and Security**→ **System**

The **System Properties** screen is displayed.

- 2 Depending upon your operating system, choose the appropriate action from the following list:
  - For Windows Server 2003:  
Click the **Hardware** tab.
  - For Windows Server 2008:  
Click **Device Manager**.
  - Windows Server 2008 R2:  
Click **Device Manager**.

The **Device Manager** screen is displayed.



**NOTE:** Alternatively open **Device Manager**. In **Windows Explorer**, right-click on **My Computer** and select **Manage**. The **Computer Management** screen is displayed. Select **Device Manager** in the left panel.

- 3 Double-click on **SCSI and RAID Controllers**.



**NOTE:** In Windows 2008, SAS is listed under **Storage Controllers**.

- 4 Double-click the controller for which you want to update the driver.
- 5 Click the **Driver** tab and click **Update Driver**.

The **Upgrade Device Driver Wizard** screen is displayed.

- 6 Make the driver files available with the USB key, or other media.
- 7 Select **Install from a list or specific location**.
- 8 Click **Next**.
- 9 Follow the steps in the wizard and browse to the location of the driver files.
- 10 Select the **.inf** file from the USB key or other media.
- 11 Click **Next** and continue the installation steps in the wizard.
- 12 Click **Finish** to exit the wizard and reboot the system for the changes to update.

## Installing the Linux Driver

To install the driver for Linux, use the procedures in this section. The driver is updated frequently. To ensure that you have the current version of the driver, download the updated Linux driver from the Dell Support website at [support.dell.com](http://support.dell.com).

### Installing the RPM Package With DKMS Support

- 1 Uncompress the gzipped tarball driver release package.
- 2 Install the DKMS package using the command: `rpm -ihv dkms-  
<version>.noarch.rpm`
- 3 Install the driver package using the command: `rpm -ihv mpt2sas-  
<version>.noarch.rpm`



**NOTE:** Use `rpm -Uvh <package name>` when updating an existing package.

- 4 If the previous device driver is in use, you must reboot the system for the updated driver to take effect.
- 5 Verify that the driver has been loaded with these system commands:  
`modinfo mpt2sas` and `dkms status`.

## Upgrading the Kernel

You must reinstall the DKMS-enabled driver packages when upgrading to a new kernel.

To update or install the driver for the new kernel:

- 1** In a terminal window, type the following:  

```
#dkms build -m <module_name> -v <module version> -k <kernel version>
```

```
#dkms install -m <module_name> -v <module version> -k <kernel version>
```
- 2** To check whether the driver is successfully installed in the new kernel, type: `dkms status`  
  
The following message is displayed: **<driver name>, <driver version>, <new kernel version>: installed**
- 3** If the previous device driver is in use, you must reboot the system for the updated driver to take effect.



## 6 Gbps SAS HBA BIOS

The BIOS of the Dell PowerEdge 6 Gbps SAS HBA and Internal Tape Adapter cards have the following features:

- Support for multiple SAS controllers
- Read-only memory (ROM) BIOS recovery image
- POST status error messaging
- POST accessible and text-based configuration utility (<Ctrl><C>).

### POST Messages

During POST, the BIOS displays messages that provide the status and identification information of the controllers, and also displays errors detected during the POST process.

The BIOS POST identification banner prints the BIOS identification, copyright information, and the controller version.

The BIOS also prompts you to start the **Configuration Utility** during the POST process.

### BIOS Fault Code Messages

If you encounter an error in the BIOS during POST, the **BIOS Configuration Utility** forces you to acknowledge BIOS errors by halting the POST process after the error display. You must press any key to continue. The **BIOS Configuration Utility** allows you to choose to continue booting or stop booting if you encounter errors.



**NOTE:** The BIOS Configuration Utility does not support system boot on devices connected to the 6 Gbps SAS HBA or the Internal Tape Adapter cards. The following message is displayed at POST to indicate that system boot is disabled for these controllers: `Adapter(s) disabled by user.`

# Configuration Utility

## Using Configuration Utility

- 1 Boot the system.
- 2 Press <Ctrl><C> during POST when prompted.  
Wait until the operating system completes bootup. Then, restart your system and try again.



**NOTE:** After you press <Ctrl><C>, press <Enter> on the adapter to manage it.



**NOTE:** The configuration utility does not offer the ability to configure tape and RBOD devices. Tape devices and RBODs have their own configuration management interface.

## Functions of the Configuration Utility

The screens are organized in a hierarchical fashion and navigation hints are displayed at the bottom of each screen.

The screens are:

- Adapter List—Lists all the 6 Gbps SAS HBA and Internal Tape Adapter cards in the system.
- Global Properties—Lists static and modifiable properties applicable to all 6 Gbps SAS HBA and Internal Tape Adapter cards in the system.
- Adapter Properties—Main screen for the selected controller. Lists the static and modifiable properties for the selected 6 Gbps SAS HBA and Internal Tape Adapter cards. Provides a menu for additional screens.
- SAS Topology—Lists the physical topology for the selected controller.
- Device Properties—Lists the properties of physical devices attached to the selected controller.
- Advanced Adapter Properties—Lists the advanced properties for the selected controller.

## Exit Screen



**NOTE:** Changes to the SAS BIOS Configuration Utility take effect only when you exit the utility.

Use the **Adapter List** and press <Esc> to save and exit the **SAS BIOS Configuration Utility**. A similar exit screen appears when you exit other **SAS BIOS Configuration Utility** screens. Use these exit screens to save your settings.



# Troubleshooting

For support and troubleshooting information on your Dell PowerEdge 6 Gbps SAS HBA or Internal Tape Adapter cards, see the Dell Support website at [support.dell.com](http://support.dell.com).

## General Issues



**NOTE:** For more troubleshooting information, see the *OpenManage Storage Services User's Guide* on the Dell Support website at [support.dell.com](http://support.dell.com).

## Configuration Utility Error Messages



**NOTE:** If the error messages are displayed even after following the resolution steps mentioned, contact Dell Support for advanced troubleshooting. For information on how to contact Dell Technical Support, see "Contacting Dell" on page 8.

- **Message:** An error occurred while reading non-volatile settings.

**Description:** An error occurs while reading one of the settings from the firmware.

**Suggested Solution:** Reseat the controller and reboot.

- **Message:** An error occurred while reading current controller settings.

**Description:** The controller setup and initialization fails.

**Suggested Solution:** Reboot the system.

- **Message:** Advanced Device Properties settings not found.

**Description:** Fails to read vital configuration page from firmware.

**Suggested Solution:** Reflash the firmware and reboot.

- **Message:** Error obtaining PHY properties configuration information.  
**Description:** Fails to read vital configuration page from firmware.  
**Suggested Solution:** Reflash the firmware and reboot.
- **Message:** Configuration Utility Options Image checksum error.  
**Description:** Fails to read **Configuration Utility** options from flash.  
**Suggested Solution:** Restart and retry. If the issue persists, reflash the firmware on the controller.
- **Message:** Can't load default Configuration Utility options.  
**Description:** Memory allocation for **Configuration Utility** options structure fails.
- **Message:** An error occurred while writing non-volatile settings.  
**Description:** An error occurs while writing one or more settings to the firmware.

## BIOS Error Messages

- **Message:** Press <Ctrl+C> to enable BIOS  
**Description:** When the BIOS is disabled, you are given the option to enable it by entering the **Configuration Utility**. You can change the setting to **Enabled** in the **Configuration Utility**.
- **Message:** Adapter configuration may have changed, reconfiguration is recommended!  
Press CTRL-C to run Dell 6 Gbps SAS HBA **Configuration Utility**...  
**Description:** Start the **Configuration Utility** and confirm the configuration of the 6 Gbps SAS HBA or Internal Tape Adapter controller.
- **Message:** Initializing...  
**Description:** This message is displayed while the BIOS is waiting to initialize.
- **Message:** SAS discovery error  
**Description:** Indicates that there is a discovery error reported by the firmware and may be accompanied by more such messages. Enter the **Configuration Utility** to investigate.
- **Message:** Device not available at HBA n, HDL n, LUN  
**Description:** Device may not be ready at this time. The device will be retried. If the problem persists, restart your system.
- **Message:** ERROR! Device is not responding to Read Capacity  
**Description:** The device does not respond to a read capacity command. Contact Dell.
- **Message:** Failed to add device, too many devices!  
**Description:** Cannot allocate resources for additional devices.
- **Message:** ERROR! Adapter Malfunctioning!  
**Description:** The adapter did not initialize properly. There may be a problem with the adapter configuration. Reload the BIOS configuration. Start the **Configuration Utility** again and see if the issue persists.

- Message:** MPT firmware fault

**Description:** The adapter did not initialize properly. There may be a problem with the adapter configuration. Reload the BIOS configuration. Start the **Configuration Utility** again and see if the issue persists.
- Message:** Updating Adapter List!

**Description:** A new adapter for which there is no record is found. A record is created for it.
- Message:** Adapter(s) disabled by user

**Description:** An adapter is found, but it is disabled in the **Configuration Utility** and will not be used by the BIOS.
- Message:** Adapter configuration may have changed, reconfiguration is suggested!

**Description:** A controller is moved or reinstalled in the system. Add it to the boot order using the available resources.
- Message:** Memory allocation failed

**Description:** The controller cannot allocate enough memory to load the **Configuration Utility**, its strings file, or its options file. Reboot the system.
- Message:** Invalid or corrupt image

**Description:** One of the images for the **Configuration Utility**, its strings file, or its options file is corrupt. Reload the BIOS. Reflash the firmware.
- Message:** Image upload failed

**Description:** Cannot upload the image for the **Configuration Utility**, its strings file, or its options file. Reload the BIOS. Reflash the firmware.
- Message:** Unable to load the Dell 6 Gbp SAS HBA Configuration Utility

**Description:** Cannot load the **Configuration Utility**. This error usually follows one of the four previous messages.
- Message:** Dell 6 Gbp SAS HBA configuration utility will load after initialization!

**Description:** <Ctrl><C> is used to start the configuration utility but insufficient memory is available. The **Configuration Utility** loads (boots) after POST initialization.



- **Message:** MPT BIOS Fault xxh encountered at adapter PCI (xxh, xxh, xxh)

**Description:**

- Fault 01: No I/O port assigned to the adapter.
  - Fault 02: A MPT firmware fault occurred.
  - Fault 03: No image for firmware download boot.
  - Fault 04: Firmware download boot checksum error.
  - Fault 05: IOC hardware error.
  - Fault 06: MPT firmware communication error.
  - Fault 07: PCI bus master error.
  - Fault 08: String image (messages) not found.
  - Fault 09: String memory allocation failed.
  - Fault 0A: String upload failed.
  - Fault 0B: String image was invalid.
  - Fault 0C: Unsupported IOC configuration.
  - Fault 0D: Time out waiting for IOC to reply.
  - Fault 0E: Transmit doorbell handshake error.
  - Fault 0F: Receive doorbell handshake error.
  - Fault 10: No memory mapped I/O address assigned.
  - Fault 11: IOC facts failure.
  - Fault 12: IOC initialization failure.
  - Fault 13: Port enable failure.
- **Message:** MPT BIOS Fault xxh encountered at adapter PCI (xxh, xxh, xxh)  
**Description:** When xxh is 02 or 11, a 4-digit hexadecimal fault value may be displayed with this message. Ensure that you make a note of this value and contact technical support for assistance.
  - **Message:** One or more unsupported device detected!  
**Description:** There is a topology error during device scan.

- **Message:** SAS Address NOT programmed on controller in slot xx  
**Description:** The SAS address (World Wide ID) equals zero and is not programmed.
- **Message:** Bus master ERROR!  
**Description:** The bus master enable was not set for the chip.

# Updating the Firmware

You can flash the firmware package to update either of the following:

- Dell PowerEdge
- 6 Gbps SAS HBA
- Internal Tape Adapter card firmware.

Flash the firmware package while the controller is in use. Restart the system for all changes to take effect. If there is a failure while flashing the firmware package (such as a power outage) the controller reverts to the earlier version of the firmware.



**NOTE:** If you flash the firmware while using the controller, you may notice temporary degradation in the controller's performance.

## Firmware Package Update Utility

You can run the firmware package update utility from a variety of operating systems. The firmware package is automated and does not require user intervention. You can obtain the firmware package flash utility from the *PowerEdge Service and Diagnostic Utilities* media that is shipped with your system.

You have to perform a manual update. For the latest firmware package updates and update procedures, see the Dell Support website at [support.dell.com](http://support.dell.com).

